

# Rapid Purger

Product Bulletin 76-00

Type: V300

## Purpose:

The V300 rapid purger from Parker is designed to safely and efficiently remove non-condensable gases from ammonia refrigeration systems. The V300 is an improvement over the successful V200 series and offers several new features and benefits.

The V300 is equipped with a RS-485 communication port for easy interface to controller data transmission. All of the parameters accessible via the HMI cable are now accessible via the serial channel. Further advancements include extended data logging time and password protection for factory calibration settings.

Like its predecessor the V200, the V300 can be used with 120 or 240 VAC and can handle from 4 to 20 purge points.



## Contact Information: Product Features:

Parker Hannifin Corporation  
**Refrigerating Specialties Division**  
2445 South 25th Avenue  
Broadview, IL 60155-3891

**phone (708) 681-6300**  
**fax (708) 681-6306**

[www.parker.com/refspec](http://www.parker.com/refspec)

- Compact design with equivalent capacity of our V200 model
- Made from 100% corrosion free components
- RS-485 communication capability
- Records purge cycles and purge time up to 12 weeks
- Password protection prevents tampering
- Multiple language display
- Factory calibrated for plug and play functionality

- Automatically adjusts vent pressures based on system conditions
- Energy saving sleep mode will activate with the lack of non-condensable gases
- Proprietary microprocessor control for all sensing
- Includes 1/2" Globe-T SW isolation valves for the liquid, foul gas and suction lines
- Includes a 30"-150 psig ammonia gauge and encapsulated leaded coils



ENGINEERING YOUR SUCCESS.

**Table of Contents**

Technical Data .....	2	Maintenance Instructions .....	19
Introduction .....	2	Parts Kit Information .....	20
Purge Cycle.....	3	Service Pointers.....	22
Installation .....	4	<b>Appendix A</b>	
Startup Instructions .....	7	Purge Point Initiation/ Termination Instructions .....	25
Nameplate Information .....	7	Setting Communications and Unit Instructions .....	27
Password Setting Instructions.....	8	Display Setting Instructions .....	28
Purge Type and Points Setting Instructions.....	9	Language Setting Instructions .....	29
Calibrate Pressure Input and RTD .....	11	Date/Time Setting Instructions .....	29
Remote Communications Setup/Assembly Instructions .....	12	Date/Time Format Setting Instructions .....	31
Adaptor Driver Installation Instructions.....	13	History Viewing Instructions .....	32
Remote Communications Setup Instructions.....	14	Clearing History Instructions .....	33
Communication Protocol.....	18	Factory Test Mode Instructions .....	34

**Technical Data**

Liquid Temperature Range .....	-20°C to 50°C (5°F to 120°F)	Maximum Rated Pressure .....	21.0 bar (305 psig)
Ambient Temperature Range .....	2°C to 54°C (35°F to 130°F)		

**Introduction**

Non-condensable gasses such as air, hydrogen, nitrogen and hydrocarbons reduce the overall efficiency of refrigeration systems. The effects of non-condensable gasses, in a refrigeration system, increase the system operating pressures. These in turn negatively effect system performance. Increased compressor discharge temperature, higher energy costs, reduced system efficiency, leaks due to higher pressures, and increased wear on mechanical components are all negative consequences of non-condensable gasses in refrigeration systems.

The build-up of non-condensable gasses in the system can be attributed to several factors. These include inadequate system evacuation during service of system equipment, additions of refrigerant, leaks through external seals on equipment as well as refrigerant, and oil decomposition.

Common indicators of non-condensable gasses in the system are excessively high condensing pressure or temperature and deviations in the pressure and temperature relationship at saturation conditions. This can be determined by checking the temperature and pressure relationship at a known point in the system where the refrigerant is saturated, such as the condenser drain legs or high pressure receiver, as illustrated in Figure 1. A higher temperature measured at this point, compared to the saturation pressure, indicates the presence of non-condensable gasses in the system.

Purging non-condensable gas from a refrigeration system can be accomplished manually, mechanically or automatically. Manual purging generally involves personnel removing air from specified purge “points” within the system through hand shut off valves routed to a water bucket. Mechanical purging is achieved by use of a device which will allow air to escape to a water reservoir when air is present. The latter method is automatic purging, which is generally achieved by the use of a self-contained system

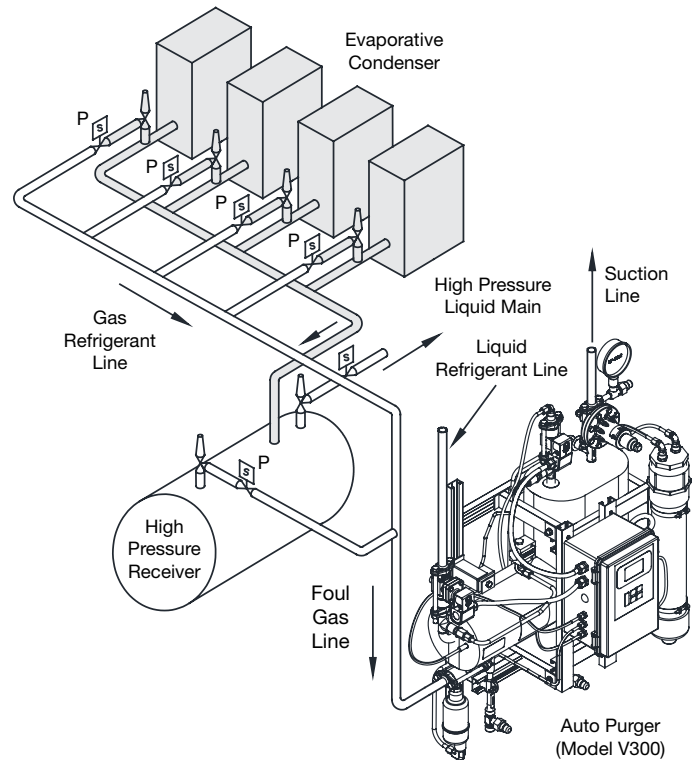

**Figure 1: Purge Point (P) Locations**

incorporating microprocessor controls. These are designed to sample the non-condensable gasses and refrigerant mixture and purge when non-condensable gasses are present.

Mechanical and automatic air purging units, commonly referred to as “purgers”, are manufactured by several companies. Each manufacturer’s purger operates in its own unique way. This article will focus specifically on the automatic purgers manufactured by Parker Hannifin Refrigerating Specialties Division.

## Purge Cycle

The purge cycle consists of three main processes: fill & pre-cool, separation of non condensable gases & refrigerant, and the safe release of the non-condensable gases.

### 1. Fill & Pre-Cool (See Figure 2 for a graphic representation of this cycle)

This cycle begins with high pressure liquid ammonia feeding through the liquid solenoid, check valve and orifice (causing expansion) into the V300’s heat exchanger. The liquid solenoid stays energized until the level of ammonia in the heat exchanger is sensed by the level sensor. The level sensor is strategically located so that all of the tubes in the heat exchanger are filled with liquid ammonia. This guarantees the highest level of performance.

The V300 Rapid Purger will stay in the “Pre-Cool” mode until the shell of the heat exchanger reaches a temperature of 4.4°C (40°F) or lower. This is determined by the temperature of the suction the purger is tied into. Once the purger reaches the required temperature, the purger will enter the active mode.

To prevent a vacuum type situation, the A2B evaporator pressure regulator, located on the return suction line, is set at 0.24 barg (3.5 psig). This will prevent the heat exchanger from reaching temperature below -29°C (-20°F).

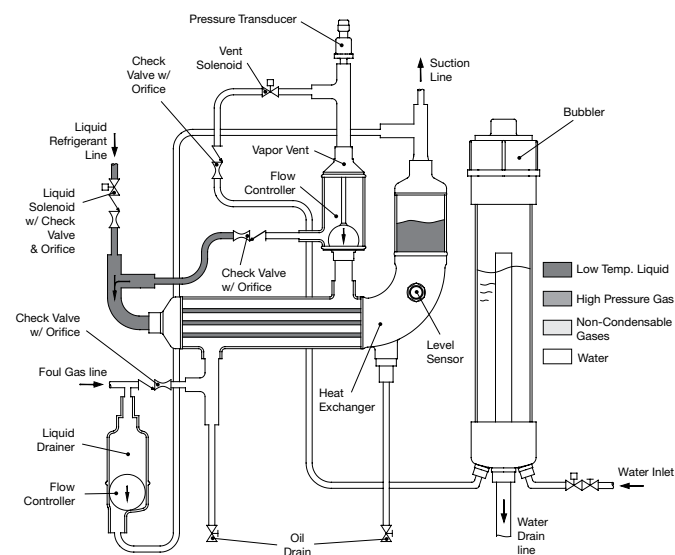

Figure 2: Purger Fill & Pre-Cool Cycle

The most common purge points in a refrigeration system are at the condenser drain, pilot receivers, thermosyphon receivers, high pressure receivers, liquid drain header, equalizing lines, and low velocity-high side areas.

Purge points should be located to ensure no liquid refrigerant is drawn into the purger. The Rapid Purger V300 has a liquid drainer at the foul gas inlet to prevent any liquid refrigerant from entering the shell side of the heat exchanger.

### 2. Separation of Non-Condensable Gases & Refrigerant (See Figure 3 for a graphic representation of this cycle)

Once the fill and pre-cool cycle reaches the desired temperature and liquid level, it selects a purge point and commences a purge cycle by activating a solenoid located on the high side of the system, as illustrated in Figure 1.

With an active purge point, the non-condensable gasses and refrigerant mix, also known as foul gas, enters the shell side of the heat exchanger through the liquid drainer, check valve and a flow control orifice. Any liquid that has condensed in the purge lines will collect in the liquid drainer and return directly to the suction. If the foul gas line does not contain condensed liquid and any remaining liquid in the liquid drainer evaporates to the suction, the liquid drainer flow control ball will prevent any foul gas from entering the suction line by blocking the orifice at the bottom of the liquid drainer tank, forcing the foul gas through the flow control orifice.

After going through the control orifice the foul gas passes over the tubes in the heat exchanger and residual refrigerant is condensed. Liquid accumulation in the shell side of the heat exchanger continues until the level reaches the differential check valve, where the liquid is recycled back

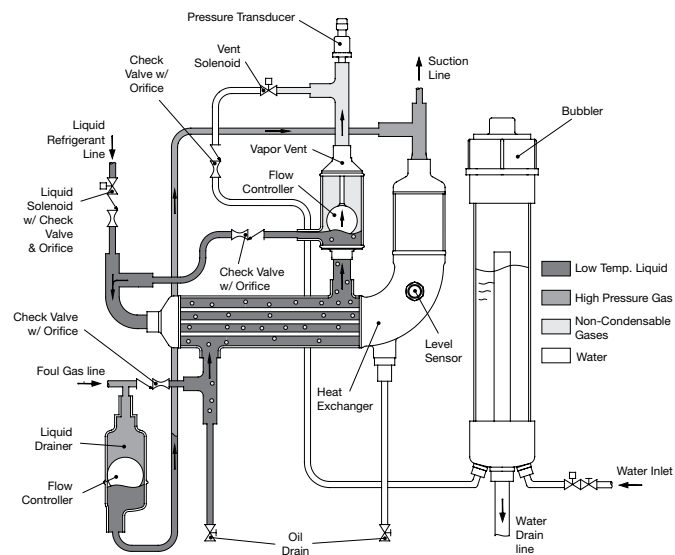

Figure 3: Purger Separation of Non-Condensable Gasses & Refrigerant Cycle

to the liquid makeup side of the heat exchanger. This "Recycling" of ammonia reduces the need to call for more makeup refrigerant to maintain the liquid level on the tube side of the heat exchanger.

The Rapid Purger V300 can only purge one point at any given time. In the separation of non-condensable gases, purging is done automatically and effectively with built in control features such as purge sampling and sleep model.

In automatic mode, each purge point is sampled for a minimum of five minutes. If the purge conditions are not met within the sample time limit, the Rapid Purger continues to the next purge point. When a purge point meets the purge conditions within the sample time limit, the Rapid Purger starts the purge cycle. The purge cycle shuts off when non-purge conditions are met.

Sleep mode allows the system to bypass purge points after two cycles of not meeting the purge conditions within the minimum sample time of five minutes. After the Rapid Purger samples each purge point twice without a vent occurring, the system will shut off for two hours.

3. Release of Non-Condensable Gases (See Figure 4 for a graphic representation of this cycle)

Non-condensable gases will continue to accumulate in the "Vapor Vent Float" chamber as it is separated from the refrigerant. Once the volume of these gases in the float chamber rises past the target pressures, based on the sampled temperature, the vent and water solenoids are energized and the non-condensable gases are released into

the water bubbler. For safe disposal, the non-condensable gases are diluted in the water.

Any oil that may collect in the V300 purger can be drained off from the two oil drains. Before draining the oil, shut-off the purger and close the liquid and foul gas valves. Allow the purger to pump out any remaining refrigerant and close the suction line valve. Use normal oil draining precautions to prevent injury or property damage

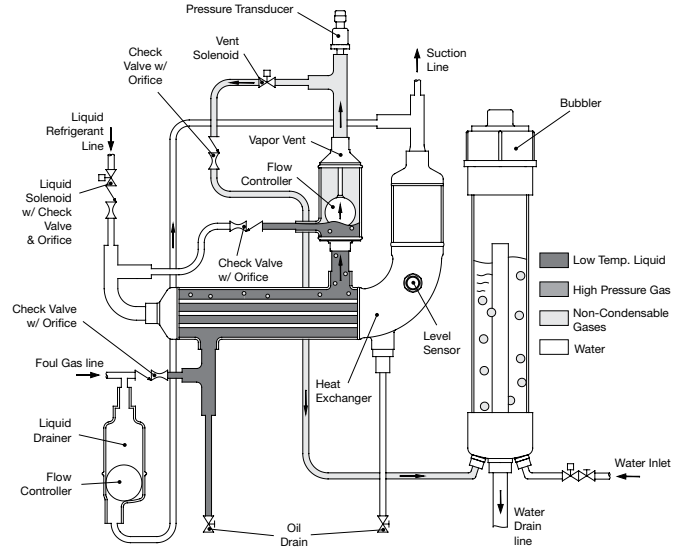

Figure 4: Purger Release of Non-Condensable Gases

Installation

All purgers are packed for a maximum protection. Unpack carefully. Check the carton to make sure all items are unpacked. Save the enclosed instructions for the installer and eventual user. Do not remove the protective coverings until the purger is ready to be installed.

The V300 Rapid Purger includes three 1/2" socket weld (SW) shut-off isolation valves used for the suction, liquid, and foul gas line. A 1/4" national pipe thread (NPT) 30-150 psig ammonia pressure gauge is also included for the monitoring suction line.

Once the purger is ready to be installed we recommend the following installation procedure. These instructions are for a new system installation. If the purger is being installed in an existing system or replacing an existing purger, the high pressure liquid, foul gas, and suction lines must be isolated and pumped out.

1. Mount the Rapid Purger to a wall or structure that can easily handle its weight and installation hardware. The approximate weight of the purger is 34.5 kg (76 lbs). Figure 5 provides dimensional information for the mounting holes, line locations and overall purger height, width and length.

If mounting the purger outside it is recommended the it be protected from the natural elements like the sun, rain, etc. The outside ambient temperature cannot exceed a range of 2°C to 54°C (35°F to 130°F).

Make sure to leave access for servicing the unit if required. The recommended clearance zone, as shown in Figure 5, is 254 mm

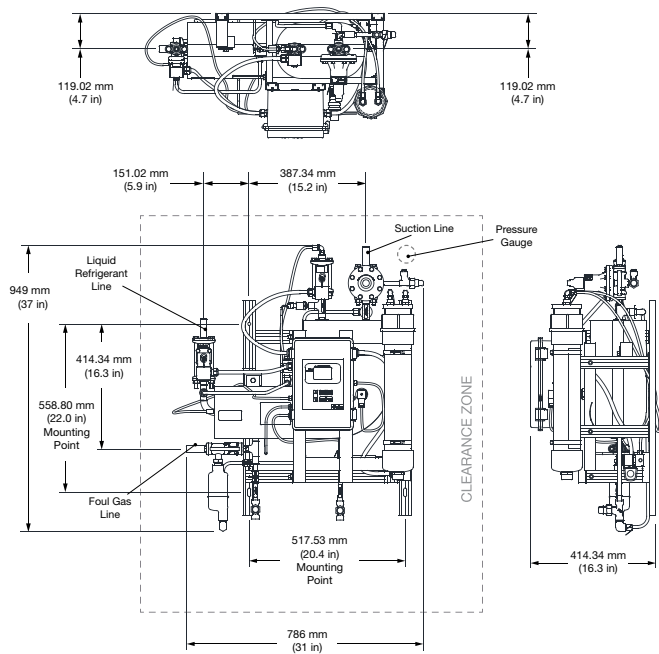

Figure 5: Purger Dimensional Information

(10") for the top and sides. The bottom of the purger must be free of obstructions to allow for water drain and oil removal.

2. Properly locate, support and align the systems high pressure liquid, foul gas and suction lines with the purger.

**Note:** To prevent oil from entering the heat exchanger and reducing performance of the purger, it is recommended to tie the liquid line in from the side or top of the desired liquid piping. We also recommended to connect the suction line from the purger to the low side system suction. This will allow setting of the A2 regulator for optimal performance down to a minimum of 0.24 barg (3.5 psig).

3. Weld in the three 1/2" SW shut-off isolation valves. Make sure the connections are free from debris and corrosion. For more installation instruction on hand shut-off valves, refer to the RSBHV safety bulletin located in the purger packet.

Before welding the systems high pressure liquid, foul gas and suction lines to the hand shut-off valves need to be in the open position. Normally, it is not necessary to disassemble valves for welding. However, if welding is prolonged enough to overheat the body, a wet rag should be wrapped around the valve bonnet and upper body during welding. The codes applicable to the welding of socket weld valves require that the pipe be inserted into the socket until bottomed against the stop. The pipe is then to be backed out approximately 1/16 of an inch before welding.

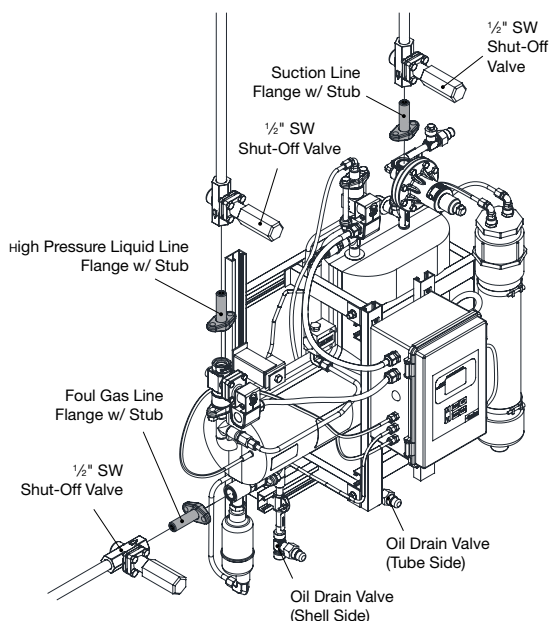

**Figure 6:** Purger Flange Line Connections

4. Remove the purger flange connections, with the welded stubs, from the high pressure liquid, foul gas and suction line. The flanges are highlighted, in gray, in Figure 6.

**⚠ WARNING**

Do not trap the foul gas line prior to entering the purger. This will cause the foul gas to condense.

5. Wait several minutes before welding the purger flanges to the hand shut-off valves. Be certain the mating surface of the flange is parallel to the mating flange and perpendicular to the pipe axis. Again, the hand shut-off valves must be in the open position prior to welding. Check the connections to make sure they are free from debris.
6. After the shut-off valves and purger flanges have been installed wait several minutes to cool down from the welding process. The hand shut-off valves must be put in the closed position to prevent any ammonia from entering the heat exchanger prior to finishing the installation. If the valves are closed before the heat dissipates from the welds, the seat can be damaged.
7. Using the same flange nuts and bolts, reconnect the flanges to the purger and tighten them progressively. For more information on flange torque specification, please reference the IAR 2-2008 Section 10 documentation.
8. Purge the water line to remove any contaminants prior to connecting it to the water feed solenoid, highlighted in gray in Figure 7. This will prevent the solenoid valve, flow switch and water lines from becoming plugged. Apply Teflon tape/paste to the 1/4" NPT threaded nipple prior to threading it into the water solenoid.
9. Install a water drain line for the bubbler. The connection for the drain line is 3/4"-14 FPT. Follow your local codes on how to properly dispose of the water after a purge.

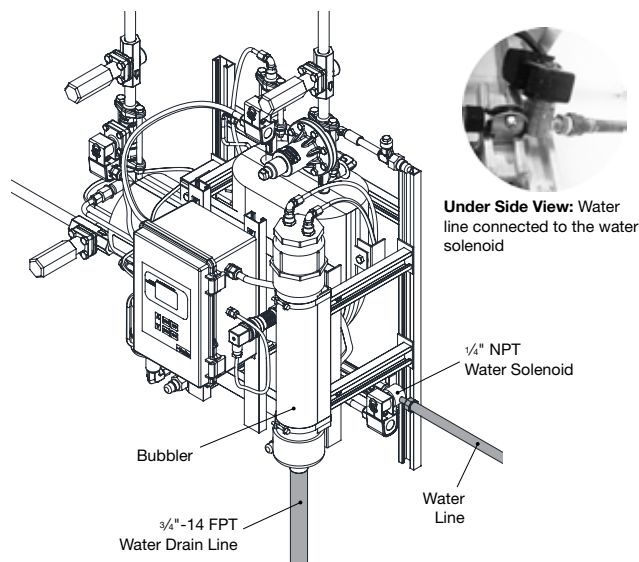

**Figure 7:** Water Line Connections

10. Check and verify both oil drain valves, shown in Figure 6, are closed by removing the seal cap and turning the adjustment stem clockwise. If the adjustment stem does not move it means the valve is fully seated. Do not over tighten; it can damage the seat and be a potential leak point.
11. Open the purger control panel to start wiring the purge points and power supply, see Figure 8 for wiring diagram. All common lines should tie together at the DIN rail terminal blocks.

Coil common, shown in Figure 8, on the purge point solenoids connections are common to the relay. Incoming line power (120/240 volts) should be supplied to these terminals. An incoming neutral should be supplied to one of each of the coil

leads. The other coil lead should be attached to the N.O. or coil neutral terminal for each independent purge point solenoid (S6N, S8F).

The terminal blocks supplied with the purger accept wire from 12-22 AWG wire. For wire sizes smaller than 12 AWG, wire pin terminals are supplied to make installation easier. It is recommended to use the pin terminals for the optimal electrical connection. The maximum allowable torque of the field wiring terminals is 0.4 Nm (3.5 in-lbs).

Input power to the controller should not exceed a maximum of 265 VAC. If voltage spikes in excess of this are expected, a surge suppressor must be installed.

On the bottom of the purger control enclosure are access ports to feed the power and purger point wire connections. Wire only one purge point solenoid to each controller contact relay.

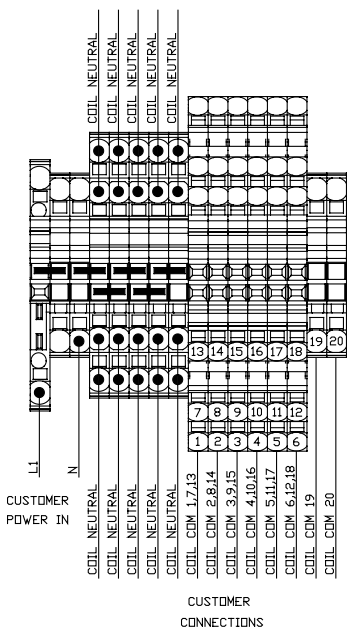

Figure 8: Purge Point & Power Wiring Diagram

**CAUTION:** The controller is not to be connected to rigid metallic conduit. Nonmetallic enclosures do not provide grounding between conduit connections. Use grounding bushings and jumper wires when connecting to metal conduit or equivalent.

12. The purger may be commissioned once the unit is properly connected to the associated piping within the ammonia system and all power connections are securely established.
13. Supply power to the purger and wait for the start up screen to display. Follow the instructions on the display screen and familiarize yourself with the control panel's interface, see Figure 9.

On startup, the purger will enter a 15 second delay. This allows the bubbler to fill with water before starting any purge cycles.

If the water bubbler does not fill to the recommended water level press and hold the (INIT) button on the controller keypad to energize the water solenoid valve. When water begins to drain from the overflow tube, release the (INIT) button to de-energize the water solenoid valve.

**WARNING:** Because both the water and vent solenoids are energized at the same time, this procedure must be done prior to opening the system to refrigeration. Failure to do so will result in venting of ammonia.

**SAFETY FEATURE:** The temperature controller and sensor are wired in series with the pressure switch. This prevents venting of non-condensed refrigerant to the water bubbler before the heat exchanger reaches the desired temperature.

If the automatic startup does not activate, the process will have to be performed manually. Press the MENU button on the control panel interface to enter the display screen and follow the startup instructions located further in the document.

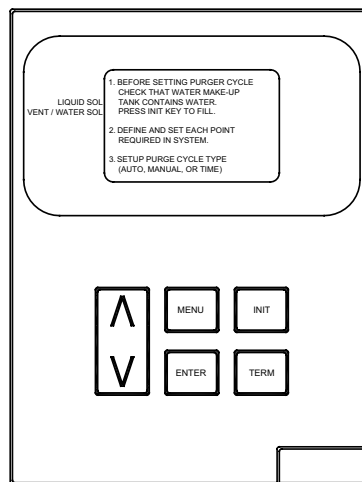

Figure 9: Control Panel - Displaying Initial Startup Screen

14. When the initial startup is complete, the startup screen can be exited by pressing the MENU button on the control panel interface. This will bring you to the main display screen where the actual temperature and pressure, target vent, active purge point, number of vents, duration of vent and solenoid activity is displayed.

The main display screen, on startup, is always in English. To change the language follow the language setting instructions located in appendix A.

15. The number of purge points for the system needs to be defined with the required sample time for each point. To setup the purge points, follow the purger type and purge points setting instructions located further in the document. The purge mode can also be set to either automatic, time based or manual purging.
16. Now that the purger is properly installed and commissioned, the high pressure liquid, foul gas, and suction lines can be opened to the purger. Slowly open each line, no order required, and check for leaks. If there no leaks, continue opening the hand shut-off valves to full open.

The purger will automatically start establishing the conditions required for purging.

All other setup instructions, such as date setup, time setup, display settings, history, etc. can be found in appendix A.

## Startup Instructions

Startup Instructions			
Steps	Setup Instructions	Display	Notes
1	To Initiate a startup, press the (MENU) button to go to the secondary menu screen	<p>MAIN MENU  <b>START UP</b>            SETUP            HISTORY            FACTORY TEST MODE            LANGUAGE MENU            SELECT WITH <math>\nabla</math> <math>\blacktriangle</math> PRESS (ENTER)            PRESS (MENU) TO RETURN</p>	
2	Use the (v) button to move the selection bar to the 'Start Up' option and then press (Enter)	<p>MAIN MENU  <b>START UP</b>            SETUP            HISTORY            FACTORY TEST MODE            LANGUAGE MENU            SELECT WITH <math>\nabla</math> <math>\blacktriangle</math> PRESS (ENTER)            PRESS (MENU) TO RETURN</p>	If the selection bar does not have 'Start Up' selected, use the ( $\blacktriangle$ ) or ( $\nabla$ ) button to move the selection bar.
3	Follow the instructions on the screen and then press (Enter)	<p>1. BEFORE SETTING PURGE CYCLE CHECK THAT WATER MAKE-UP TANK CONTAINS WATER.            2. DEFINE AND SET EACH POINT REQUIRED IN THE SYSTEM.            3. SETUP PURGE CYCLE TYPE (AUTO, MANUAL, OR TIME).            PRESS (ENTER) TO CONTINUE</p>	

## Nameplate Information

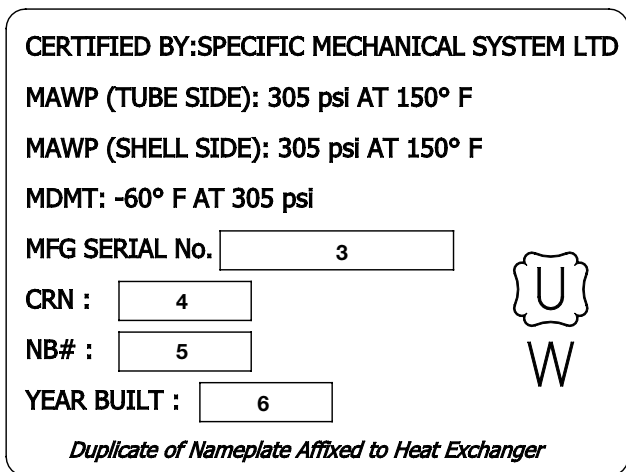
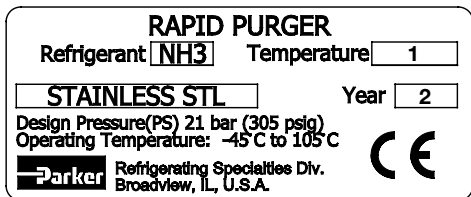

Item	Description
1	Cartridge Model
2	Year of Manufacture, Complete V300 Purger
3	Serial Reference Number
4	Canadian Registration Number (CRN)
5	National Board Number (NB#)
6	Year of Manufacture, Heat Exchanger

Table 1 : V300 Rapid Purger Nameplate Identification

Figure 10: V300 Rapid Purger Nameplates

## Password Setting Instructions

Password Setting Instructions			
Steps	Setup Instructions	Display	Notes
1	To set the Password for calibrating the Pressure Input or the RTD, press the (MENU) button to go to the secondary menu screen		
2	Use the (v) button to move the selection bar to the 'Setup' option and then press (Enter)		If the selection bar does not have the 'Setup' option selected, use the (Λ) or (v) button to move the selection bar.
3	Use the (v) button to move the selection bar to 'Set Password' and then press (Enter)		If the selection bar does not have the 'Set Password' option selected, use the (Λ) or (v) button to move the selection bar.
4	Use the (Λ) and (v) buttons followed by (Enter) for each of the four digits of the password		The Password change screen will not be accessible without the correct password
5	Enter the new password by using the (Λ) and (v) buttons followed by (Enter) for each of the four digits of the password.		
6	Confirm the new password by using the (Λ) and (v) buttons followed by (Enter) for each of the four digits of the password.		After the new password is confirmed, press (Enter) twice to return to the Main Screen.



## Purge Type and Points Setting Instructions

Purge Type and Points Setting Instructions			
Steps	Setup Instructions	Display	Notes
1	To change the purge type, press the (MENU) button to go to the main menu screen.		
2	Use the (v) button to move the selection bar to the SETUP option.		If the selection bar does not have the 'Setup' option selected, use the (A) or (v) button to move the selection bar.
3	Use the (v) button to move to 'Purge Options' and Press (Enter) again to enter the Purge Options selectable		If the selection bar does not have 'Purge Options' selected, use the (A) or (v) button to move the selection bar.
4	In the Purge Options menu select 'Select Purge Type' or 'Setup Points' and press (Enter)		If 'Select Purge Type' is selected, then jump to Step 5 If 'Setup Points' is selected, then jump to Step 13
5	In the Select Purge Type menu, select either Auto, Manual, or Time-Based by using the (A) or (v) button to move the selection bar and press (Enter)		If 'Auto' is selected, then jump to Step 13 If 'Manual' is selected, then jump to Step 13 If 'Time-Based' is selected, then jump to Step 6
6	Use the (A) or (v) buttons to enter the start time hour for the purge cycle to begin every day		Time-Based purging establishes the same time block every day for the purger to be active. The Purger will be in sleep mode for all times outside of this daily time block.
7	Use the (A) or (v) buttons to enter the start time minute within the hour set in Step 6 for the purge cycle to begin every day		If the Purge time is set for Greenwich Mean Time (GMT), jump to Step 8 If the Purger time is set for Military Time, jump to Step 9
8	Use the (A) or (v) buttons to select the start meridiem, 'AM' or 'PM'		
9	Use the (A) or (v) buttons to enter the end time hour for the purge cycle to begin every day		To cancel the operation, press (Menu) to return to the beginning of the Start Time setting screens

**Purge Type and Points Setting Instructions Continued**

Purge Type and Points Setting Instructions													
Steps	Setup Instructions	Display	Notes										
10	Use the (Λ) or (∇) buttons to enter the end time minute within the hour set in Step 9 for the purge cycle to begin every day	<p>SET PURGER END TIME</p> <p>ENTER THE MINUTE: 20</p> <p>SELECT WITH ∇ ▲ PRESS (ENTER) PRESS (MENU) TO GO BACK TO SETTING START TIME</p>	If the Purge time is set for Greenwich Mean Time (GMT), jump to Step 11 If the Purger time is set for Military Time, jump to Step 12										
11	Use the (Λ) or (∇) buttons to select the end meridiem, 'AM' or 'PM'	<p>SET PURGER END TIME</p> <p>SELECT AM / PM: PM</p> <p>SELECT WITH ∇ ▲ PRESS (ENTER) PRESS (MENU) TO GO BACK TO SETTING START TIME</p>											
12	This screen gives the opportunity to check if all the values for Time-Based purging are correct. If everything entered is correct, press (Enter) to make the changes	<p>START / END TIME REVIEW</p> <p>PLEASE REVIEW SETTING: START TIME: 9:05 AM END TIME: 11:20 PM</p> <p>SELECT WITH ∇ ▲ PRESS (ENTER) PRESS (MENU) TO GO BACK TO SETTING STOP TIME</p>	To cancel the operation, press (Menu) to return to the beginning of the Stop Time setting screens										
13	Use the (Λ) or (∇) buttons to select the number of Purge Points in the system	<p>SETUP POINTS</p> <p>HOW MANY POINTS ARE NEEDED? 04</p> <p>SELECT WITH ∇ ▲ PRESS (ENTER) PRESS (MENU) TO GO BACK</p>											
14	Use the (Λ) or (∇) buttons to select the specific purge point that needs its Duration altered and press (Enter)	<table border="1"> <thead> <tr> <th>POINT</th> <th>DURATION</th> </tr> </thead> <tbody> <tr> <td>01</td> <td>20 MIN</td> </tr> <tr> <td>02</td> <td>15 MIN</td> </tr> <tr> <td><b>03</b></td> <td><b>10 MIN</b></td> </tr> <tr> <td>04</td> <td>20 MIN</td> </tr> </tbody> </table> <p>SELECT WITH ∇ ▲ PRESS (ENTER) PRESS (MENU) TO RETURN</p>	POINT	DURATION	01	20 MIN	02	15 MIN	<b>03</b>	<b>10 MIN</b>	04	20 MIN	
POINT	DURATION												
01	20 MIN												
02	15 MIN												
<b>03</b>	<b>10 MIN</b>												
04	20 MIN												
15	When the purge point is selected, press (Enter) to allow the respective duration to be selectable	<table border="1"> <thead> <tr> <th>POINT</th> <th>DURATION</th> </tr> </thead> <tbody> <tr> <td>01</td> <td>20 MIN</td> </tr> <tr> <td>02</td> <td>15 MIN</td> </tr> <tr> <td>03</td> <td>▶ 10 MIN</td> </tr> <tr> <td>04</td> <td>20 MIN</td> </tr> </tbody> </table> <p>SELECT WITH ∇ ▲ PRESS (ENTER) PRESS (MENU) TO RETURN</p>	POINT	DURATION	01	20 MIN	02	15 MIN	03	▶ 10 MIN	04	20 MIN	The Duration options are 5 min, 10 min, 15 , and 20 min
POINT	DURATION												
01	20 MIN												
02	15 MIN												
03	▶ 10 MIN												
04	20 MIN												
16	Use the (Λ) or (∇) buttons to select the duration of a particular purge point and then press (Enter) to set the duration	<table border="1"> <thead> <tr> <th>POINT</th> <th>DURATION</th> </tr> </thead> <tbody> <tr> <td>01</td> <td>20 MIN</td> </tr> <tr> <td>02</td> <td>15 MIN</td> </tr> <tr> <td>03</td> <td>▶ 10 MIN</td> </tr> <tr> <td>04</td> <td>20 MIN</td> </tr> </tbody> </table> <p>SELECT WITH ∇ ▲ PRESS (ENTER) PRESS (MENU) TO RETURN</p>	POINT	DURATION	01	20 MIN	02	15 MIN	03	▶ 10 MIN	04	20 MIN	
POINT	DURATION												
01	20 MIN												
02	15 MIN												
03	▶ 10 MIN												
04	20 MIN												
17	Repeat steps 14-16 until all the purge points have the desired durations												

## Calibrate Pressure Input and RTD

Calibrate Pressure Input and RTD			
Steps	Setup Instructions	Display	Notes
1	To calibrate the Pressure Input or the RTD, press the (MENU) button to go to the secondary menu screen		
2	Use the (v) button to move the selection bar to the 'Setup' option and then press (Enter)		If the selection bar does not have the 'Setup' option selected, use the (Λ) or (v) button to move the selection bar.
3	Use the (v) button to move the selection bar to either 'Calibrate Pressure Input' or 'Calibrate RTD (Temperature)' and then press (Enter).		If 'Calibrate Pressure Input' is selected, jump to Step 4 If 'Calibrate RTD (Temperature)' is selected, jump to Step 8
4	Use the (Λ) and (v) buttons followed by (Enter) for each of the four digits of the password		The Pressure input valves will not be accessible without the correct password
5	Use the (Λ) and (v) buttons to select the minimum pressure and press (Enter) to set the value		The default value is the factory calibrated value
6	Use the (Λ) and (v) buttons to select the maximum pressure and press (Enter) to set the value		The default value is the factory calibrated value
7	This screen gives the opportunity to check if all the values for calibrating the pressure input are correct. If everything entered is correct, press (Enter) to make the changes		Press (Enter) two more times to get back to the Main Menu
8	Use the (Λ) and (v) buttons followed by (Enter) for each of the four digits of the password		
9	Use the (Λ) and (v) buttons to set the ambient RTD temperature and press (Enter) to set the value		The default value is the factory calibrated value Press (Enter) two more times to get back to the Main Menu

## Remote Communications Setup/Assembly Instructions

The V300 Rapid Purger is equipped with a RS-485 communication port for easy interface to controller data transmission. To make the connection from the CAT5 Ethernet cable (RJ45 plug) to the computer. Refrigerating Specialties recommends using the Gearmo GM-482422 USB to RS-485/422 interface converter, see Figure 11 below.



**Figure 11:** RS-485/422 Interface Converter

To connect the CAT5 Ethernet cable to the GM-482422 converter follow below instructions.



1. Measure the length of the CAT5 cable from the V300 Rapid Purger to the computer.
2. Cut off one end of the CAT5 cable to expose the internal wires.
3. Strip the ends of the of the white/blue, solid blue and solid brown cables.
4. Fasten the white/blue CAT 5 wire to Pin 1, 485+, on the Gearmo adaptor.
5. Fasten the solid blue CAT 5 wire to Pin 2, 485-, on the Gearmo adaptor.
6. Fasten the white/blue CAT 5 wire to Pin 5, GRD, on the Gearmo adaptor.
7. The cable is now ready for use.

For remote communications setup follow the Parker GUI, option 1, or the customer customized GUI, option 2, located further in this bulletin.

Connection Pole	Data Output	RS-422 Full Duplex	RS-485 Half Duplex
1	T/R+	Send (A+)	RS-485 (A+)
2	T/R-	Send (B-)	RS-485 (B-)
3	RXD+	Receive (A+)	N/C
4	RXD-	Receive (B-)	N/C
5	GND	Ground Wire	Ground Wire

**Table 2:** RS-485, RS-422 Data Output, Connector, and Bay-Line Distribution

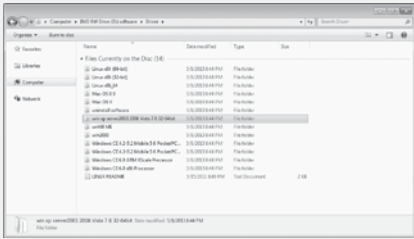
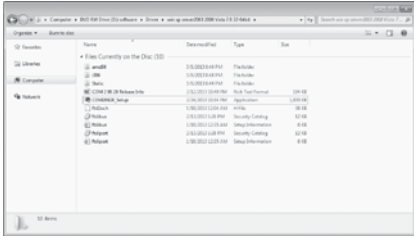
## Gearmo USB to RS485 Adaptor Driver Installation Instructions

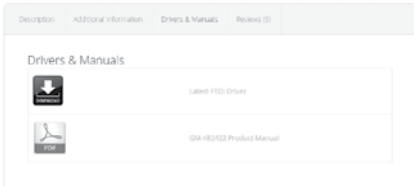
Gearmo USB to RS485 Adaptor Driver Installation Instructions			
Steps	Setup Instructions	Display	Notes
1	Insert the Gearmo FTDI driver CD into the computer of choice's CD-drive.		<p>The driver is also available for download at <a href="http://www.gearmo.com/shop/usb-to-rs485-rs422-converter-ftdi-chip-with-terminals/">http://www.gearmo.com/shop/usb-to-rs485-rs422-converter-ftdi-chip-with-terminals/</a>                      If you choose to download the driver, proceed to Step 5</p> <p>These instructions will show how to install the driver on a computer running Windows 7.</p> <p>Windows XP, 2003, Vista, 7, 8 as well as Linux and Mac OS 10.X are supported</p>
2	Open the folder labelled 'Driver' located in the drive containing the Gearmo CD (D: drive).		
3	Now open the folder which corresponds to the operating system on your computer of choice, in this case it is 'win xp server 2003 2008 Vista 7 8 32-64bit'		
4	Double click the executable file labelled 'CDM20828_Setup' and follow the on-screen instructions to install the driver.		
5	Following the link from Step 1 will show the information page on the Gearmo adapter. Under the 'Drivers & Manuals' tab on this page, select 'Latest FTDI Driver' to download the driver installation file.		
6	Open the ZIP folder labelled 'FTDI-Latest' when the download is complete. Double-click the executable file in this folder and follow the on-screen instructions to install the driver.		

## Remote Communications Setup Instructions - Option 1

Remote Communications Setup Instructions - Option 1			
Steps	Setup Instructions	Display	Notes
1	Install the program (RS485 V300 Purger Interface V1.1.exe) on the desired computer.		
2	Run the 'RS485 V300 Purger Interface V1.3.exe' Application.		Download the remote com interface at <a href="http://www.ParkerRealSolutions.com">www.ParkerRealSolutions.com</a>
3	Connect the USB side of the USB/RS485 cable to the computer.		
4	Open the V300 Purger Controller enclosure by unlatching the two side latches.		
5	Feed the other end of the cable (RS485 side) through an unused hole at the bottom of the V300 Purger Controller enclosure.		
6	Plug in the RS845 (Cat5) connector to the RJ45 Jack on the Display Board affixed to the backside of the Enclosure lid.		The adaptor's driver should be installed on the laptop for the w port to be recognized.
7	If you are running the Remote Communications on a Windows Operating System, access 'Device Manager' through 'Control Panel'. Under 'Ports (COM & LPT)', double-click the COM port that aligns with the RS-485 converter.		In order for the Remote Communications Interface to run properly, the COM port settings on the computer of choice, V300 Purger Controller, and Purger Interface Application must match.
8	The following window will appear. Select 'Port Settings' and ensure that 'Bits per second' is 19200, and 'Parity' is Even. Then click 'Advanced'		

## Remote Communications Setup Instructions - Option 1 Continued

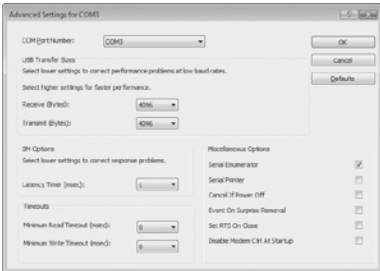
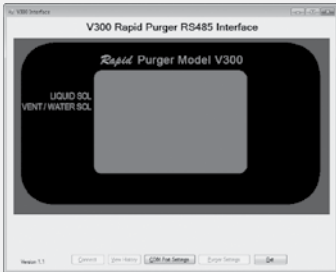
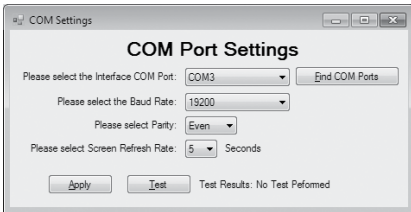
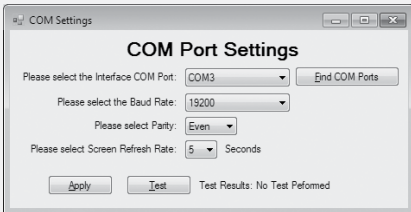
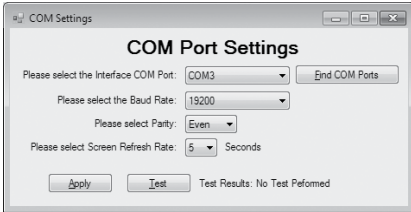
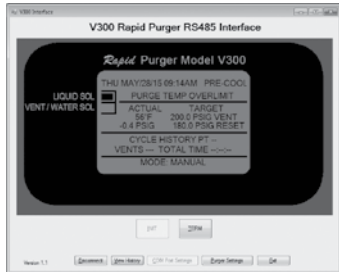
Remote Communications Setup Instructions - Option 1			
Steps	Setup Instructions	Display	Notes
9	The following window will appear. Ensure that 'Receive' and 'Transmit' are both set to 4096, and that 'Latency Timer' is set to 1.		
10	Click on the 'COM Port Settings' in the Remote Communications application to set up the COM Port.		
11	Select the COM port that is associated with the RS485 cable.		It is important to select the correct COM port that aligns with the RS-485 converter. This can be determined by starting the application on the PC with the RS485 converter unplugged from the V300 Purger Controller, then look at the COM ports that are available on the Bootloader. Then, plug in the RS485 converter and click 'Find COM Ports' in the application. The additional COM port that appears is the port that should be selected.
12	Set the Baud Rate to '19200' Set the Parity to 'Even' Keep the Refresh Rate to '5' Seconds		
13	Press 'Apply' to set the parameters and return to the Main Screen. Then press 'Connect' on the Main Screen to establish a connection.		<p>If connection is properly established, the real time display will appear in the remote communications application:</p> 
			From here on, remote monitoring and setting is enabled via the application.

Remote Communications Setup Instructions - Option 1 Continued

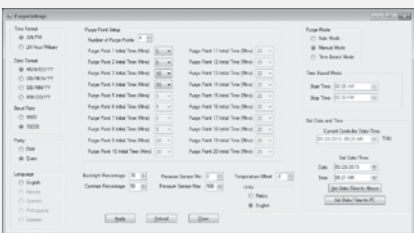
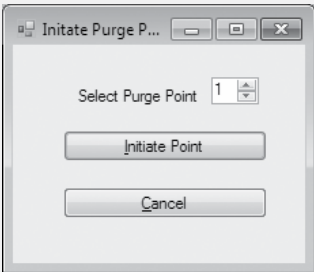
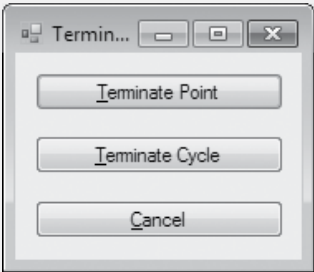
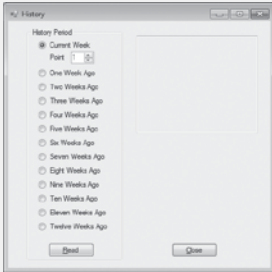
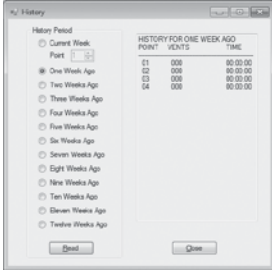
Remote Communications Setup Instructions - Option 1			
Steps	Setup Instructions	Display	Notes
14	Click 'View History' on the Main Page To update any parameter, select 'Purge setting'		To set any parameter, press 'Apply'
15	To Initiate a manual purge, select 'INIT' on the Main Screen		
16	The following screen will appear. Select the purge point in question and press 'Initiate Point' to start.		
17	To terminate a purge, select 'TERM' on the Main Screen		
18	The following screen will appear. Select 'Terminate Point' to terminate the current purge point and cycle to the next. Select 'Terminate Cycle' to end purging completely.		
19	Click 'View History' on the Main Page to view the last 12 weeks of history.		
20	The following screen will appear. Here, select any date in time and press 'read' to get a history for the week in question.		If current week is selected, point by point observations can be viewed
21	The screen will show the number of vents and total vent time at each purge point for a given week.		



## Remote Communications Setup Instructions - Option 2

Remote Communications Setup Instructions - Option 2			
Steps	Setup Instructions	Display	Notes
1	Use the Protocol list 'MSC_114-PURGE2_COMMUNICATIONS TABLE' to create a Customer Graphical User Interface.		Can set up to Integrate directly into Main control panel.
2	Open the custom Application.		
3	Connect the USB side of the USB/RS485 cable to the computer.		
4	Open the V300 Purger Controller enclosure by unlatching the two side latches.		
5	Feed the other end of the cable (RS845 side) through an unused hole at the bottom of the V300 Purger Controller enclosure.		Feed from the outside to the inside.
6	Plug in the RS845 (Cat5) connector to the RJ45 Jack on the Display Board affixed to the backside of the Enclosure lid.		
7	Establish communication with the V300 Purger through the custom application.		
8	Navigate the application to monitor and set parameters as desired.		

## Communication Protocol

V300 RS485 Communication Protocol						
Variable (TX Data)	Start Header HEX	Variable HEX	Data Length ASCII	Data sent using ASCII (No Error) ASCII	Carriage Return HEX	Checksum Single Byte Checksum (HEX)
timeformat	0x01	0x41	1	1 = AM/PM, 2 = 24HR	0x0D	=VALUE(1) * 1 + VALUE(2) * 2 + VALUE(n) * n
dateformat	0x01	0x42	1	1 = MON/DD/YY, 2 = DD/MON/YY, 3 = DD/MM/YY, 4 = MM/DD/YY	0x0D	=VALUE(1) * 1 + VALUE(2) * 2 + VALUE(n) * n
SetPurgePoints	0x01	0x43	2	Number of Points, 01 - 20	0x0D	=VALUE(1) * 1 + VALUE(2) * 2 + VALUE(n) * n
Password	0x01	0x44	4	4 digits 0-9 (####)	0x0D	=VALUE(1) * 1 + VALUE(2) * 2 + VALUE(n) * n
Baud	0x01	0x45	1	1 = 9600, 2 = 19200	0x0D	=VALUE(1) * 1 + VALUE(2) * 2 + VALUE(n) * n
Parity	0x01	0x46	1	1 = ODD, 2 = EVEN	0x0D	=VALUE(1) * 1 + VALUE(2) * 2 + VALUE(n) * n
Temp_Scale	0x01	0x47	1	1 = C, 2 = F	0x0D	=VALUE(1) * 1 + VALUE(2) * 2 + VALUE(n) * n
Backlight_Pct	0x01	0x48	3	Backlight percentage, 000 - 100%	0x0D	=VALUE(1) * 1 + VALUE(2) * 2 + VALUE(n) * n
Contrast_Pct	0x01	0x49	3	Contrast percentage 000 - 100%	0x0D	=VALUE(1) * 1 + VALUE(2) * 2 + VALUE(n) * n
Temp1_Offset	0x01	0x4A	2 (3)	Temperature Offset -30 to 30	0x0D	=VALUE(1) * 1 + VALUE(2) * 2 + VALUE(n) * n
Pressure_Max	0x01	0x4B	3	Pressure max in PSI, 300 to 750	0x0D	=VALUE(1) * 1 + VALUE(2) * 2 + VALUE(n) * n
Pressure_Min	0x01	0x4C	2	Pressure min in PSI, 00 to 50	0x0D	=VALUE(1) * 1 + VALUE(2) * 2 + VALUE(n) * n
PurgeType	0x01	0x4D	1	1 = AUTO, 2 = MANUAL, 3 = TIME BASED	0x0D	=VALUE(1) * 1 + VALUE(2) * 2 + VALUE(n) * n
TimeModeStartHour	0x01	0x4E	2	Start Hour, 00 to 23	0x0D	=VALUE(1) * 1 + VALUE(2) * 2 + VALUE(n) * n
TimeModeStartMin	0x01	0x4F	2	Start Minute, 00 to 59	0x0D	=VALUE(1) * 1 + VALUE(2) * 2 + VALUE(n) * n
TimeModeEndHour	0x01	0x50	2	Stop Hour, 00 to 23	0x0D	=VALUE(1) * 1 + VALUE(2) * 2 + VALUE(n) * n
TimeModeEndMin	0x01	0x51	2	Stop Minute, 00 to 59	0x0D	=VALUE(1) * 1 + VALUE(2) * 2 + VALUE(n) * n
Current Min	0x01	0x53	2	Current Time Minutes, 00 to 59	0x0D	=VALUE(1) * 1 + VALUE(2) * 2 + VALUE(n) * n
Current Hour	0x01	0x54	2	Current Time Hours, 00 to 23	0x0D	=VALUE(1) * 1 + VALUE(2) * 2 + VALUE(n) * n
Current DoW	0x01	0x55	1	Current Time Day of Week (0 is Sunday, 1 is Monday, 2 is Tuesday, 3 is Wednesday, 4 is Thursday, 5 is Friday, 6 is Saturday)	0x0D	=VALUE(1) * 1 + VALUE(2) * 2 + VALUE(n) * n
Current Date	0x01	0x56	2	Current Day of Month, 01 to 31 (set month and year first to ensure that the day of month is valid for the current month)	0x0D	=VALUE(1) * 1 + VALUE(2) * 2 + VALUE(n) * n
Current Month	0x01	0x57	2	Current Month, 01 to 12	0x0D	=VALUE(1) * 1 + VALUE(2) * 2 + VALUE(n) * n
Current Year	0x01	0x58	2	Current Year, 00 to 99	0x0D	=VALUE(1) * 1 + VALUE(2) * 2 + VALUE(n) * n
SleepMode	0x01	0x5A	0	No Data, Read Only	0x0D	=VALUE(1) * 1 + VALUE(2) * 2 + VALUE(n) * n
SleepTimeMins	0x01	0x5B	0	No Data, Read Only	0x0D	=VALUE(1) * 1 + VALUE(2) * 2 + VALUE(n) * n
SleepTimeHours	0x01	0x5C	0	No Data, Read Only	0x0D	=VALUE(1) * 1 + VALUE(2) * 2 + VALUE(n) * n
TargetVentPressure	0x01	0x5D	0	No Data, Read Only	0x0D	=VALUE(1) * 1 + VALUE(2) * 2 + VALUE(n) * n
TargetResetPressure	0x01	0x5E	0	No Data, Read Only	0x0D	=VALUE(1) * 1 + VALUE(2) * 2 + VALUE(n) * n
ActualPressure	0x01	0x5F	0	No Data, Read Only	0x0D	=VALUE(1) * 1 + VALUE(2) * 2 + VALUE(n) * n
LiquidState	0x01	0x60	0	No Data, Read Only	0x0D	=VALUE(1) * 1 + VALUE(2) * 2 + VALUE(n) * n
VentState	0x01	0x61	0	No Data, Read Only	0x0D	=VALUE(1) * 1 + VALUE(2) * 2 + VALUE(n) * n
ActivePoint	0x01	0x62	0	No Data, Read Only	0x0D	=VALUE(1) * 1 + VALUE(2) * 2 + VALUE(n) * n
ActivePointMinutes	0x01	0x63	0	No Data, Read Only	0x0D	=VALUE(1) * 1 + VALUE(2) * 2 + VALUE(n) * n
ActivePointSeconds	0x01	0x64	0	No Data, Read Only	0x0D	=VALUE(1) * 1 + VALUE(2) * 2 + VALUE(n) * n
ActualTemp	0x01	0x65	0	No Data, Read Only	0x0D	=VALUE(1) * 1 + VALUE(2) * 2 + VALUE(n) * n
PurgeTime	0x01	0x66-0x79 (20 points)	2	Purge times, valid data is 05, 10, 15, 20	0x0D	=VALUE(1) * 1 + VALUE(2) * 2 + VALUE(n) * n
CurrentPgPtVents	0x01	0x7A	0	No Data, Read Only	0x0D	=VALUE(1) * 1 + VALUE(2) * 2 + VALUE(n) * n
CurrentPgPtHours	0x01	0x7B	0	No Data, Read Only	0x0D	=VALUE(1) * 1 + VALUE(2) * 2 + VALUE(n) * n
CurrentPgPtMins	0x01	0x7C	0	No Data, Read Only	0x0D	=VALUE(1) * 1 + VALUE(2) * 2 + VALUE(n) * n
CurrentPgPtSecs	0x01	0x7D	0	No Data, Read Only	0x0D	=VALUE(1) * 1 + VALUE(2) * 2 + VALUE(n) * n
ReadHistory	0x01	0x7E	5	2 Bytes for Week (00 = current, 01 = one week ago thru 12 = twelve weeks ago). 2 Bytes for Purge Point to retrieve history for (01 to 20). One Byte for Day of Week (0 = SUN, 6 = SAT)	0x0D	=VALUE(1) * 1 + VALUE(2) * 2 + VALUE(n) * n

## Communication Protocol Continued

V300 RS485 Communication Protocol						
Variable (TX Data)	Start Header HEX	Variable HEX	Data Length ASCII	Data sent using ASCII (No Error) ASCII	Carriage Return HEX	Checksum Single Byte Checksum (HEX)
InitScreen	0x01	0x7F	0	No Data, Read Only	0x0D	=VALUE(1) * 1 + VALUE(2) * 2 + VALUE(n) * n
Terminate Point	0x01	0x80	1	1 = Terminate Current Point, 2 = Terminate Cycle	0x0D	=VALUE(1) * 1 + VALUE(2) * 2 + VALUE(n) * n
Initiate Point	0x01	0x81	2	2 Bytes are for the purge point number 01-20.	0x0D	=VALUE(1) * 1 + VALUE(2) * 2 + VALUE(n) * n
InitScreenControl	0x01	0x82	1	0 = Do nothing (not filling Bubbler) 1 = Exit Init Screen, 2 = Filling Bubbler	0x0D	=VALUE(1) * 1 + VALUE(2) * 2 + VALUE(n) * n

ASCII to Hex Conversion	
ASCII Number	HEX Value
0	0x30
1	0x31
2	0x32
3	0x33
4	0x34
5	0x35
6	0x36
7	0x37
8	0x38
9	0x39

## Maintenance Instructions

Maintenance Instructions	
Procedure	Instructions
Oil Draining	<p>Review your facilities procedures on how to properly pump down and drain oil from a vessel before attempting to drain oil from the purger heat exchanger. The following instructions are a recommendation and may not fall within the PM program of your facility.</p> <ol style="list-style-type: none"> <li>Follow the facilities oil draining procedures on how to properly extract oil from a vessel. The RSBCV safety bulletin, located in the purger packet, provides additional safety and pump out instructions. Read these instructions prior on continuing to the next step.</li> <li>The purger heat exchanger must be isolated and pumped out before removing the oil. Close the hand shut-off valves to the high pressure liquid and foul gas line. Keep the suction hand shut-off valve open to pump down the heat exchanger. <b>Note:</b> The purger controller can remain powered through the draining oil maintenance procedure.</li> <li>Manually open the SV2 solenoid, #6 in the exploded view, on the high pressure liquid line by removing the seal cap and turning the manual opening stem clockwise until only the flats on the end of the stem protrude from the packing nut. This will prevent liquid ammonia from being trapped between the liquid hand shut-off valve and SV2 solenoid.</li> <li>Use the HSBR level switch as an ammonia level indicator. When the LEDs turn off, the system will call for liquid, but the liquid hand shut-off valve is preventing any additional liquid from entering the purger, pumping out the heat exchanger.</li> <li>Allow the purger to pump out a few more minutes before closing the suction line hand shut-off valve. The remaining ammonia in the system will pressurize the vessel and assist in draining the oil.</li> <li>Purge one oil drain line at a time. Slowly crack open the shell side oil drain valve, see Figure 6, and discharge the oil into the proper container accepted by safety codes and standards. <b>WARNING:</b> Do not open the oil drain valves completely.</li> <li>When the oil is done draining close the oil drain valve.</li> <li>Repeat steps 6 thru 7 for the tube side oil drain valve.</li> <li>After draining all the oil from the purger heat exchanger the system is ready to go back online. Return the SV2 solenoid valve back to automatic mode by turning the stem counter clockwise as far as it will go. Loosen the packing nut before turning the stem and re-tighten after the stem out.</li> <li>Slowly open each line, no order required, and check for leaks. If there are no leaks continue opening the hand shut-off valves to full open. The purger will automatically start establishing the conditions required for purging.</li> </ol>

Parts Kit Informaton

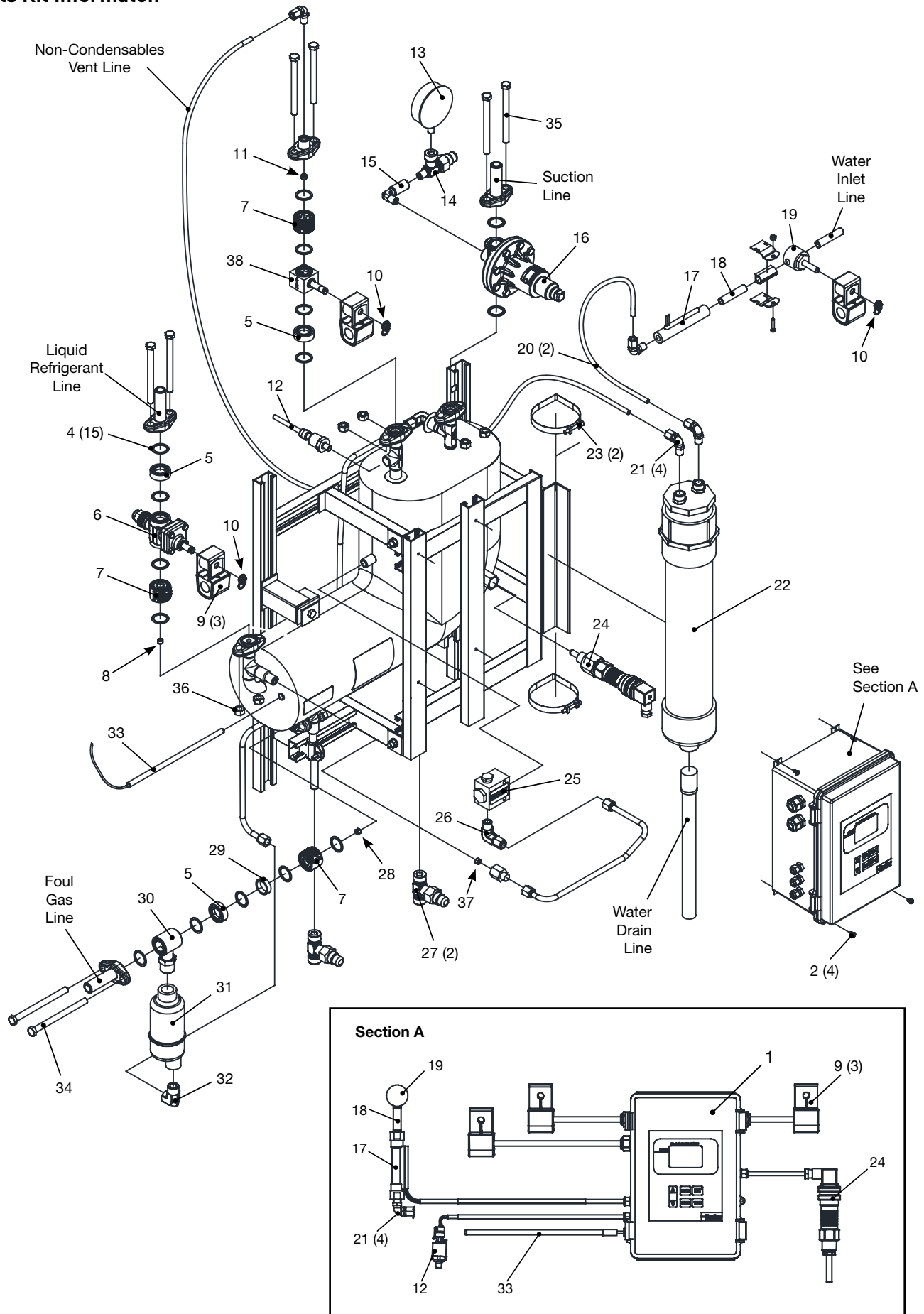

Figure 12: V300 Auto Purger Exploded View

Item	Description	Kit Description	Kit
1	Controller, V300	120V Controller	
2	Connecting Bolts, Controller	4 Point	209898
9(3)	Coil, Solenoid Valve	8 Point	209899
10	Retaining Clip, Coil	12 Point	209900
12	Pressure Transducer	16 Point	209901
17	Flow Switch, Water Line	20 Point	209902
18	Pipe, Threaded	240V Controller	
19	Solenoid Valve, Water Line	4 Point	209924
21	Nylon Connector, Elbow	8 Point	209925
24	Level Switch, HBSR	12 Point	209926
33	Temperature Probe	16 Point	209927
		20 Point	209928
4(12)	Gasket, Flange	Gasket Pkg, Flange	202078
4(2)	Gasket, Flange		
5	Disc Strainer	Strainer Assembly, Disc	200912
4(2)	Gasket, Flange		
6	Solenoid Valve, SV2	Solenoid Valve Assembly, Liquid Line	209369
4(2)	Gasket, Flange		
7	Check Valve, CK4A-2 (1/2" NPT)	Check Valve Assembly	CK413X00NSN
8	Orifice, 0.040" (1/8" NPT)	Plug Pkg, Orifice 0.040"	208667
9	Coil, Solenoid Valve	Coil Pkg	
10	Retaining Clip, Coil	110-120V ~ 50-60Hz	209073
		220-240V ~ 50-60Hz	209074
10(12)	Retaining Clip, Coil	Retaining Clip Pkg	206516
11	Orifice, 0.026" (1/8" NPT)	Plug Pkg, Orifice 0.026"	208665
12	Pressure Transducer	Pressure Transducer	209292
13	Pressure Gauge, Ammonia	Pressure Gauge 760mm - 10.5 bar 30" - 150psig	309403 309401
14	Angle, Unibody (1/4" NPT)	Angle Unibody Asseby	106630
16	Pressure Regulator	Pressure Regulator, A2B RA	209290
17	Flow Switch, Water	Flow Switch Assembly	209324
18	Pipe, Threaded		
19	Solenoid Valve, Water Line	Solenoid Valve Assembly, Water Line	208787
21	Nylon Connector, Elbow		
20(6)	Nylon Tubing		
21(4)	Nylon Connector, Elbow	Nylon Tubing, Bubbler	208668
22	Water Bubbler	Water Bubbler Assembly	208789
24	Level Switch, HBSR	Level Switch Assembly	208790
25	Differential Check Valve, (50psig)	Differential Check Valve Assembly	309657
27	Unibody, Globe (1/4" NPT)	Globe Unibody Assembly	106621
28	Orifice, 0.032" (1/8" NPT)	Plug Pkg, Orifice 0.032"	208666
4(2)	Gasket, Flange		
29	13mm (1/2") Ring Adaptor	Ring Adaptor	200095
31	Liquid Drainer	Liquid Drainer	309625
33 [1]	Temperature Probe	Temperature Probe, Sensor	209075
37	Orifice, 0.028" (1/8" NPT)	Plug Pkg, Orifice 0.028"	209365
38	Solenoid Valve, S6P	Solenoid Valve Assembly, Vent Line	208982

**Table 3:** V300 Rapid Purger Repair Kits

1 Should the RTD require replacement, the factory setting must be changed in order to calibrate the RTD. Close the hand valve for the foul gas inlet and liquid feed inlet. Remove the faulty RTD and connect the replacement RTD to the proper wiring. Place the RTD in a container with ice and water. Observe the temperature reading on the controller screen and wait for it to stabilize. Once the temperature has stabilized change the offset to cause the temperature reading to be 0°C (32°F). Double check the reading in the ice water bath and ensure that the RTD is reading 0°C (32°F). The RTD is now calibrated.

## Service Pointers

V300 Service Pointer		
Symptom	Possible Cause	Solution
Water bubbler cloudy	Water supply turned off.	Open water supply ball valve supplied with purger. Check water solenoid coil for proper operation (Loose wire, burned out). Replace if necessary.
	Hard water.	Used treated water (softened). Clean bubbler on regular bases to prevent severe clouding.
	Venting ammonia.	Check vent solenoid for proper operation. If bubbles are seen in the water bubbler when idling, vent solenoid is leaking. Clean or replace solenoid if needed.
	Cloudy bubbler	Clean the bubbler using a long handle bottle brush and a cleaning agent such as CLR®, Lime-A-Way® or vinegar can be used to remove the water scale.
Purger stays in "Pre-Cool" mode, will not purge.	Suction too high.	Verify Suction is below 4.4°C (40°F) - 4.0 bar (58.4 psig) for R-717. Adjust the A2 suction regulator to maintain 3 psig (If in or near a vacuum). If suction is above 3 psig, remove setting from A2 regulator by turning stem counter clock wise until it stops.
	Liquid NH <sub>3</sub> supply off or obstructed.	Check liquid ammonia solenoid, S6P, for proper operation (Loose wire, burned out). Replace if necessary. Check controller display for "Liquid Solenoid" pilot light. Segment should be darkened if liquid is required. This is located on the upper left side of the front panel (#1). Check level sensor for proper operation (Loose wire, defective sensor). Replace if necessary. Check liquid supply orifice for obstructions. Clean or replace if necessary.
	RTD not reading accurately or no display.	Note: RTD is factory calibrated and no field adjustment is required. If the main controller displays " _ _ _ " rather than an actual temperature reading, check for loose wires. Check wire loom from main board to cover for loose or damaged wires/ connections. Replace RTD if necessary.
No temperature reading on controller display.	Loose RTD connection.	Check for loose wires connecting the RTD to the main controller board.
	Loose or damaged wire loom connecting front panel to main board.	Check wire loom from main board to cover for loose or damaged wires/ connections.
	Faulty RTD.	Check resistance range of the RTD (100 ohm +/- 0.1%) Replace RTD if necessary.
No pressure reading on controller display.	Loose wire connection.	Note: pressure transducer is factory calibrated and no field adjustment is required. Check for loose wires connecting the pressure transducer to the main controller board.
	Faulty pressure transducer.	Replace pressure transducer if necessary.
Purger reaches target pressure, vent solenoid will not open	Water is not available	Check water supply line to purger and ensure water is available Check water solenoid coil for proper operation Check water solenoid valve for blockage
	Water flow switch is faulty	Replace water flow switch
	Purge solenoid coil faulty	Check solenoid coil for proper operation, replace if necessary
Water is supplied to water solenoid valve but no flow is present		Check water supply line to purger and ensure water is available Check water solenoid coil for proper operation Check water solenoid valve for blockage <b>ADVISORY</b> - The water supply should use softened or filtered water to prevent calcification or deposits which could block the water solenoid valve. If softened/filtered water is not available premature failure of the water solenoid valve may result.

## Service Pointers Continued

V300 Service Pointer		
Symptom	Possible Cause	Solution
Strong Ammonia smell coming from bubbler (#22).	Water make up closed or restricted.	<p>Make sure the fresh water supply to the bubbler is not turned off or being restricted.</p> <p>Check the operation of the water makeup solenoid. Verify that the coil is energized when the vent cycle is active. The magnetic field can be verified with a small screwdriver touching the top of the solenoid tube. It should be drawn to the tube if the coil is powered and functioning properly. If the coil functions and water still does not flow to the bubbler, check the supply lines for obstructions.</p> <p>Use filtered/soft water.</p> <p>Replace the water solenoid, #19 in the exploded view, if necessary.</p>
	Leaking vent solenoid.	<p>If bubbles are seen in the bubbler well after a vent has occurred, the vent solenoid may be leaking.</p> <p>Replace the solenoid if necessary.</p>
Controller in "sleep mode", will not purger	No foul gas present in system.	The purger controller will automatically go into "Sleep Mode" if it has sampled every programmed purge point twice without a vent occurring. It will stay in sleep mode for 2 hours then resume its programmed cycle. You can override the sleep mode cycle by simply pressing the "Enter" key on the controller. The sleep mode feature will not be disabled and will repeat again if no vent occurs.
Purger display goes black (full contrast)	Coil interference	<p><b>ADVISORY</b> - It is recommended that Refrigerating Specialties coils be used with the Refrigerating Specialties Rapid Purger for optimal performance. If the use of Refrigerating Specialties coils is not an option, coils with an inrush current rating of less than 1.22 amps MUST be used.</p> <p>If this symptom is presented it is recommended that an RC filter or MOV suppressor be added to the coil common line to prevent disruption of the display.</p>
Power is supplied to controller but the purger does not turn on	Blown fuse	Replace fuse on common (L1) terminal block.
	Poor connection on common/neutral the inputs	Check common/neutral connections into junction box.
	Improper wiring	Ensure that common/neutral wiring matches the wiring diagram.
	Faulty controller	Replace controller assembly.
High temperature	Oil built up in the heat exchanger	Drain oil from the heat exchanger. Follow maintenance procedures located in this bulletin.
Data communication failure		<p>Make sure USB interface connection is correct.</p> <p>Make sure RS-485/RS-422 output interface connection is correct.</p> <p>Make sure power supply is OK.</p> <p>Make sure the wire terminal connection is OK.</p> <p>Make sure the pilot lamp flashes when receiving.</p> <p>Make sure the pilot lamp flashes when sending.</p>
Data missing or incorrect		Check to see whether if the data rate and format at both ends of the communication equipment are consistent.



**APPENDIX**



### Purge Point Initiation/ Termination Instructions

Purge Point Initiation/ Termination Instructions									
Steps	Setup Instructions	Display	Notes						
1	To initiate a purge when 'No Active Points' are present, press (Init)	<p>THU MAY/21/15 04:10PM WAIT</p> <p>LIQUID SOL VENT / WATER SOL</p> <p>NO ACTIVE POINTS</p> <table border="1"> <tr> <td>ACTUAL</td> <td>TARGET</td> </tr> <tr> <td>16°F</td> <td>99.3 PSIG VENT</td> </tr> <tr> <td>56.4 PSIG</td> <td>79.3 PSIG RESET</td> </tr> </table> <p>CYCLE HISTORY PT -- VENTS --- TOTAL TIME ---:---:---</p> <p>MODE: MANUAL</p>	ACTUAL	TARGET	16°F	99.3 PSIG VENT	56.4 PSIG	79.3 PSIG RESET	<p>Purge type must be set to 'Manual'</p> <p>To initiate a purge in sleep mode, proceed to Step 11</p>
ACTUAL	TARGET								
16°F	99.3 PSIG VENT								
56.4 PSIG	79.3 PSIG RESET								
2	Use the (Λ) or (v) buttons to choose the 'Manual Purge Point' to initiate, then press (Enter) to select.	<p>CHOOSE MANUAL PURGE POINT: 01</p> <p>ADJUST PURGE POINT WITH ▼ ▲ PRESS (ENTER) TO SELECT PRESS (MENU) TO CANCEL</p>							
3	To terminate the purge point, press (Term)	<p>THU MAY/21/15 04:10PM PURGING</p> <p>LIQUID SOL VENT / WATER SOL</p> <p>ACTIVE POINT: 01 03:51</p> <table border="1"> <tr> <td>ACTUAL</td> <td>TARGET</td> </tr> <tr> <td>16°F</td> <td>99.3 PSIG VENT</td> </tr> <tr> <td>56.4 PSIG</td> <td>79.3 PSIG RESET</td> </tr> </table> <p>CYCLE HISTORY PT 01 VENTS 071 TOTAL TIME 01:45:56</p> <p>MODE: MANUAL</p>	ACTUAL	TARGET	16°F	99.3 PSIG VENT	56.4 PSIG	79.3 PSIG RESET	To terminate a purge point in Auto mode, proceed to Step 6
ACTUAL	TARGET								
16°F	99.3 PSIG VENT								
56.4 PSIG	79.3 PSIG RESET								
4	Use the (Λ) or (v) buttons to move the selection bar to 'Terminate Active Point 01' and press (Enter)	<p>TERMINATE PURGE MENU</p> <p><b>TERMINATE ACTIVE POINT 01</b></p> <p>TERMINATE PURGE CYCLE</p> <p>SELECT WITH ▼ ▲ PRESS (ENTER) PRESS (MENU) TO RETURN</p>	Selecting 'Terminate Purge Cycle' while in auto mode will produce the same results						
5	The screen now indicates that 'No Active Points' are present	<p>THU MAY/21/15 04:10PM WAIT</p> <p>LIQUID SOL VENT / WATER SOL</p> <p>NO ACTIVE POINTS</p> <table border="1"> <tr> <td>ACTUAL</td> <td>TARGET</td> </tr> <tr> <td>16°F</td> <td>99.3 PSIG VENT</td> </tr> <tr> <td>56.4 PSIG</td> <td>79.3 PSIG RESET</td> </tr> </table> <p>CYCLE HISTORY PT -- VENTS --- TOTAL TIME ---:---:---</p> <p>MODE: MANUAL</p>	ACTUAL	TARGET	16°F	99.3 PSIG VENT	56.4 PSIG	79.3 PSIG RESET	
ACTUAL	TARGET								
16°F	99.3 PSIG VENT								
56.4 PSIG	79.3 PSIG RESET								
6	To terminate a purge point in Auto mode, press (term)	<p>THU MAY/21/15 04:10PM PURGING</p> <p>LIQUID SOL VENT / WATER SOL</p> <p>ACTIVE POINT: 01 03:51</p> <table border="1"> <tr> <td>ACTUAL</td> <td>TARGET</td> </tr> <tr> <td>16°F</td> <td>99.3 PSIG VENT</td> </tr> <tr> <td>56.4 PSIG</td> <td>79.3 PSIG RESET</td> </tr> </table> <p>CYCLE HISTORY PT 01 VENTS 071 TOTAL TIME 01:45:56</p> <p>MODE: AUTO</p>	ACTUAL	TARGET	16°F	99.3 PSIG VENT	56.4 PSIG	79.3 PSIG RESET	To terminate the purge cycle, proceed to Step 9
ACTUAL	TARGET								
16°F	99.3 PSIG VENT								
56.4 PSIG	79.3 PSIG RESET								
7	Use the (Λ) or (v) buttons to move the selection bar to 'Terminate Active Point 01' and press (Enter)	<p>TERMINATE PURGE MENU</p> <p><b>TERMINATE ACTIVE POINT 01</b></p> <p>TERMINATE PURGE CYCLE</p> <p>SELECT WITH ▼ ▲ PRESS (ENTER) PRESS (MENU) TO RETURN</p>							
8	The screen now indicates that 'Active Point 02' has begun purging	<p>THU MAY/21/15 04:10PM PURGING</p> <p>LIQUID SOL VENT / WATER SOL</p> <p>ACTIVE POINT: 02 04:54</p> <table border="1"> <tr> <td>ACTUAL</td> <td>TARGET</td> </tr> <tr> <td>15°F</td> <td>78.3 PSIG VENT</td> </tr> <tr> <td>39.0 PSIG</td> <td>58.3 PSIG RESET</td> </tr> </table> <p>CYCLE HISTORY PT 02 VENTS 000 TOTAL TIME 00:00:00</p> <p>MODE: AUTO</p>	ACTUAL	TARGET	15°F	78.3 PSIG VENT	39.0 PSIG	58.3 PSIG RESET	<p>To cycle to the next purge point, repeat Steps 6-7</p> <p>If Steps 6-7 are repeated until the purge cycle has looped twice, the system will enter 'Sleep' mode</p> <p>If there is only one purge point, the system will restart 'Purge Point 01'</p>
ACTUAL	TARGET								
15°F	78.3 PSIG VENT								
39.0 PSIG	58.3 PSIG RESET								
8.5	To begin terminating the purge cycle, press the (Term) button.	<p>THU MAY/21/15 04:10PM PURGING</p> <p>LIQUID SOL VENT / WATER SOL</p> <p>ACTIVE POINT: 01 03:51</p> <table border="1"> <tr> <td>ACTUAL</td> <td>TARGET</td> </tr> <tr> <td>16°F</td> <td>99.3 PSIG VENT</td> </tr> <tr> <td>56.4 PSIG</td> <td>79.3 PSIG RESET</td> </tr> </table> <p>CYCLE HISTORY PT 01 VENTS 071 TOTAL TIME 01:45:56</p> <p>MODE: AUTO</p>	ACTUAL	TARGET	16°F	99.3 PSIG VENT	56.4 PSIG	79.3 PSIG RESET	
ACTUAL	TARGET								
16°F	99.3 PSIG VENT								
56.4 PSIG	79.3 PSIG RESET								

Purge Point Initiation/Termination Instructions Continued

Purge Point Initiation/ Termination Instructions			
Steps	Setup Instructions	Display	Notes
9	Use the (Λ) or (∇) buttons to move the selection bar to 'Terminate Purge Cycle' and press (Enter)		Terminating the purge cycle will always change the mode to Manual
10	The screen now indicates that 'No Active Points' are present and the mode has changed to Manual		
11	To initiate a purge in 'Sleep' mode, press (init)		Initiating in Auto mode will start the first purge point
12	The screen now indicates that 'Active Point 01' has begun purging		

## Setting Communications and Unit Instructions

Setting Communications and Unit Instructions			
Steps	Setup Instructions	Display	Notes
1	To set the RS485 communications or change units from Metric to English, visa versa, press the (▲) or (▼) buttons at the same time, from the main screen, to get into the settings menu.		The baud rate and parity are for RS485 communication. Default: BAUD Rate: 19200 PARITY: EVEN
2	Use the (▲) or (▼) buttons to select between the baud rate, parity or temperature scale options.		To change units select the temperature scale option.
3	After moving the selection bar to the option you would like to change press the (ENTER) button.		
4	Use the (▲) or (▼) buttons to make parameter changes within the selected option.		In this example English units was changed to Metric.
5	Press the (ENTER) button when done making changes.		This will take you back to the settings menu and the (▲) and (▼) buttons can be used to make other option selections.
6	Press the (MENU) button to return to the main screen.		Now the main screen is displayed in Metric units.

## Display Setting Instructions

Display Setting Instructions			
Steps	Setup Instructions	Display	Notes
1	To change the screen contrast or backlight brightness press the (ENTER) and (TERM) buttons at the same time to get into the display settings menu.		To enter the display settings menu screen the controller must be in the main screen.
2	To change the contrast move the selection bar to CONTRAST ADJUST, if not already there, by using the (A) and (V) buttons and then press the (ENTER) button.		If the selection bar does not have the contrast adjust option selected, use the (A) or (V) button to move the selection bar.
3	Use the (A) or (V) button to increase or decrease the contrast.		The contrast bar indicates the level at which the contrast is currently at. Pressing (A) button increases the contrast and (V) button decreases the contrast.
4	Press the (ENTER) button to return to the display setting menu screen.		
5	To change the backlight move the selection bar to BACKLIGHT ADJUST by pushing (V) button and then press the (ENTER) button.		
6	Use the (A) or (V) button to increase or decrease the backlight brightness.		The backlight brightness bar indicates the level at which the brightness of the backlight is current at. Pressing (A) button increases the brightness and (V) button decreases the brightness.
7	Press the (ENTER) button to return to the display setting menu or (MENU) button to return to the main menu screen if changing the backlight brightness is not desired.		
8	Press the (MENU) button to return to the main screen.		

## Language Setting Instructions

Language Setting Instructions			
Steps	Setup Instructions	Display	Notes
1	To change the language for the text on the display, press the (MENU) button to go to the secondary menu screen		
2	Use the (v) button to move the selection bar to the 'Language Menu' option and then press (Enter)		If the selection bar does not have 'Language Menu' selected, use the (A) or (v) button to move the selection bar.
3	Use the (A) or (v) button to move the selection bar to the desired language and then press (Enter)		Press (Menu) to return to the Main Menu screen

## Date/Time Setting Instructions

Date/Time Setting Instructions			
Steps	Setup Instructions	Display	Notes
1	To change the date press the (MENU) button to go to the main menu screen.		To enter the main menu screen the controller must be in the main screen.
2	Use the (v) button to move the selection bar to the SETUP option.		If the selection bar does not have the setup option selected, use the (A) or (v) button to move the selection bar.
3	Press (ENTER) again to enter the SET DATE AND TIME option.		If the selection bar does not have the set date and time option selected, use the (A) or (v) button to move the selection bar.
4	In the set date and time menu select the SET DATE AND TIME option and press (ENTER).		If the selection bar does not have the set date and time option selected, use the (A) or (v) button to move the selection bar.
5	Select the current year by using the (A) or (v) button to increase or decrease the year. When the year is selected, press (ENTER) to continue to next screen.		To cancel the operation, press (MENU) to return to the set date and time menu. Follow step 13 of the date/time setting instructions to exit to the main menu screen.

**Date/Time Setting Instructions Continued**

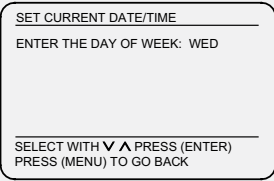
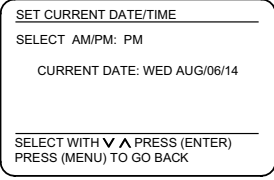
Date/Time Setting Instructions			
Steps	Setup Instructions	Display	Notes
6	Select the current month by using the (▲) or (▼) button. When the month is selected, press (ENTER) to continue to next screen.		To cancel the operation, press (MENU) to return to the set date and time menu. Follow step 13 of the date/time setting instructions to exit to the main menu screen.
7	Select the current date by using the (▲) or (▼) button. When the date is selected, press (ENTER) to continue to next screen.		To cancel the operation, press (MENU) to return to the set date and time menu. Follow step 13 of the date/time setting instructions to exit to the main menu screen.
8	Select the current day of the week by using the (▲) or (▼) button. When the day of the week is selected, press (ENTER) to continue to next screen.		To cancel the operation, press (MENU) to return to the set date and time menu. Follow step 13 of the date/time setting instructions to exit to the main menu screen.
9	Select the current hour by using the (▲) or (▼) button. When the hour is selected, press (ENTER) to continue to next screen.		To cancel the operation, press (MENU) to return to the set date and time menu. Follow step 13 of the date/time setting instructions to exit to the main menu screen.
10	Select the current minute by using the (▲) or (▼) button. When the minute is selected, press (ENTER) to continue to next screen.		To cancel the operation, press (MENU) to return to the set date and time menu. Follow step 13 of the date/time setting instructions to exit to the main menu screen.
11	Select the correct period of day by using the (▲) or (▼) button. When the period of day is selected, press (ENTER) to continue to next screen.		To cancel the operation, press (MENU) to return to the set date and time menu. Follow step 13 of the date/time setting instructions to exit to the main menu screen.
12	This screen gives the opportunity to check if all the values for date and time are correct. If everything entered is correct, press (ENTER) make the changes and return to the set date and time menu.		To cancel the operation, press (MENU) to return to the set date and time menu. Follow step 13 of the date/time setting instructions to exit to the main menu screen.
13	When complete setting up date and time press (MENU) three additional times to return to main screen.		

## Date/Time Format Setting Instructions

Date Format Setting Instructions			
Steps	Setup Instructions	Display	Notes
1	To change the date format press the (MENU) button to go to the main menu screen.		To enter the main menu screen the controller must be in the main screen.
2	Use the (v) button to move the selection bar to the SETUP option.		If the selection bar does not have the setup option selected, use the (A) or (v) button to move the selection bar.
3	Press (ENTER) again to enter the SET DATE AND TIME option.		If the selection bar does not have the set date and time option selected, use the (A) or (v) button to move the selection bar.
4	In the set date and time menu, select the SET DATE FORMAT option and press (ENTER).		If the selection bar does not have the set date format option selected, use the (A) or (v) button to move the selection bar.
5	In the set date format menu, select a month/date/year format by using the (A) or (v) button to move the selection bar and press (ENTER).		<p>Month (MON) - Example: AUG                      Month (MM) - Two digit number                      Date (DD) - Two digit number                      Year (YY) - Last two digits of the year</p> <p>When complete setting up date formatting and if there are no other changes, press (MENU) four times to return to main menu screen.</p>
6	Press (MENU) once to return to the set date and time menu.		
7	To change the set time format use the (v) button to move the selection bar to the SET TIME FORMAT option.		If the selection bar does not have the set time format option selected, use the (A) or (v) button to move the selection bar.
8	In the set time format menu select a hour format by using the (A) or (v) button to move the selection bar and press (ENTER).		Two options available: Greenwich Mean time (GMT) or Military time
9	When complete setting up date and time formatting press (MENU) four times to return to main screen.		

## History Viewing Instructions

History Viewing Instructions			
Steps	Setup Instructions	Display	Notes
1	To view the History, press the (MENU) button to go to the secondary menu screen		
2	Use the (v) button to move the selection bar to the 'History' option and then press (Enter)		If the selection bar does not have 'History' selected, use the (A) or (v) button to move the selection bar.
3	Use the (A) or (v) button to move the selection bar to the 'Read Point History' option and then press (Enter)		
4	To view the current week's history press (Enter) when the selection bar highlights 'This Week'		
5	On this screen, you can observe Purge Point number, Day, Vents, and total time of vents		Vents represents the total vents on a given Day and Purge Point Time represents the total time of all vents on a given Day and Purge Point
6	To toggle to a history for a different purge point, press the (A) or (v) button		The purge point number will be displayed on the upper left hand corner. If you are done with viewing History, press (Menu) four times to return to the Main Menu
7	Press (Menu) to return to the 'Select History Period' screen		
8	To view history for a previous week, use the (A) or (v) button to toggle to the week of choice and then press (Enter)		
9	This screen shows all the purge points and their respective number of vents and total vent times		Repeat Steps 7-8 to view a different week of purging history. Press (Menu) four times to return to the Main Menu



## Clearing History Instructions

Clearing History Instructions			
Steps	Setup Instructions	Display	Notes
1	To clear the History, press the (MENU) button to go to the secondary menu screen	<p>MAIN MENU</p> <p>START UP SETUP HISTORY FACTORY TEST MODE LANGUAGE MENU</p> <p>SELECT WITH <math>\nabla</math> <math>\blacktriangle</math> PRESS (ENTER) PRESS (MENU) TO RETURN</p>	
2	Use the ( $\nabla$ ) button to move the selection bar to the 'History' option and then press (Enter)	<p>MAIN MENU</p> <p>START UP SETUP HISTORY FACTORY TEST MODE LANGUAGE MENU</p> <p>SELECT WITH <math>\nabla</math> <math>\blacktriangle</math> PRESS (ENTER) PRESS (MENU) TO RETURN</p>	If the selection bar does not have 'History' selected, use the ( $\blacktriangle$ ) or ( $\nabla$ ) button to move the selection bar.
3	Use the ( $\blacktriangle$ ) or ( $\nabla$ ) button to move the selection bar to the 'Clear History' option and then press (Enter)	<p>HISTORY MENU</p> <p>READ POINT HISTORY CLEAR HISTORY</p> <p>SELECT WITH <math>\nabla</math> <math>\blacktriangle</math> PRESS (ENTER) PRESS (MENU) TO RETURN</p>	
4	Press 'Init' to start the history clearing	<p>PLEASE CONFIRM HISTORY CLEAR</p> <p>PRESS (INIT) TO START THE HISTORY CLEAR. ANY OTHER BUTTON PRESS WILL CANCEL THE CLEARING OF HISTORY</p>	If you wish not to clear history, press any other key besides (Init)
5	This screen indicates that history is being cleared	<p>CLEARING HISTORY</p> <p>HISTORY IS BEING CLEARED THIS WILL TAKE 5 - 10 SECS THEN RETURN TO MAIN SCREEN</p>	The screen will automatically go to the Main Menu screen after the history is successfully cleared

## Factory Test Mode Instructions

Factory Test Mode Instructions			
Steps	Setup Instructions	Display	Notes
1	To perform a factory test, press the (MENU) button to go to the secondary menu screen		
2	Use the (v) button to move the selection bar to the 'Factory Test Mode' option and then press (Enter)		If the selection bar does not have 'Factory Test Mode' selected, use the (^) or (v) button to move the selection bar.
3	Enter the new password by using the (^) and (v) buttons followed by (Enter) for each of the four digits of the password.		
4	Observe the Factory test sequence initiate.		If a failure occurs, the screen will display the failure mode.



---

**Safe Operation (See Bulletin RSBCV)**

People doing any work on a refrigeration system must be qualified and completely familiar with the system and the Refrigerating Specialties Division valves involved, or all other precautions will be meaningless. This includes reading and understanding pertinent Refrigerating Specialties Division Product Bulletins and Safety Bulletin RSB prior to installation or servicing work.

Where cold refrigerant liquid lines are used, it is necessary that certain precautions be taken to avoid damage which could result from liquid expansion. Temperature increase in a piping section full of solid liquid will cause high pressure due to the expanding liquid which can possibly rupture a gasket, pipe or valve. All hand valves isolating such sections should be marked, warning against accidental closing, and must not be closed until the liquid is removed. Check valves must never be installed upstream of solenoid valves, or regulators with electric shut-off, nor should hand valves upstream of solenoid valves or downstream of check valves be closed until the liquid has been removed.

It is advisable to properly install relief devices in any section where liquid expansion could take place. Avoid all piping or control arrangements which might produce thermal or pressure shock.

For the protection of people and products, all refrigerant must be removed from the section to be worked on before a valve, strainer, or other device is opened or removed. Flanges with ODS connections are not suitable for ammonia service.

**Warranty**

All Refrigerating Specialties products are under warranty against defects in workmanship and materials for a period of one year from date of shipment from factory. This warranty is in force only when products are properly installed, field assembled, maintained, and operated in use and service as specifically stated in Refrigerating Specialties Catalogs or Bulletins for normal refrigeration applications, unless otherwise approved in writing by the Refrigerating Specialties Division. Defective products, or parts thereof returned to the factory with transportation charges prepaid and found to be

defective by factory inspection, will be replaced or repaired at Refrigerating Specialties option, free of charge, F.O.B. factory. Warranty does not cover products which have been altered, or repaired in the field, damaged in transit, or have suffered accidents, misuse, or abuse. Products disabled by dirt or other foreign substances will not be considered defective.

The express warranty set forth above constitutes the only warranty applicable to Refrigerating Specialties products, and is in lieu of all other warranties, expressed or implied, written including any warranty of merchantability, or fitness for a particular purpose. In no event is Refrigerating Specialties responsible for any consequential damages of any nature whatsoever. No employee, agent, dealer or other person is authorized to give any warranties on behalf of Refrigerating Specialties, nor to assume, for Refrigerating Specialties, any other liability in connection with any of its products.

**ISO 9001 CERTIFIED**