

HB Products – dedicated to optimal solutions for level measurement and control of oil and refrigerants.

HB Products is a development-oriented company, which specialises in the development and production of sensors for industrial refrigeration systems. Apart from expertise within oil and refrigerant control, we have great know-how in the design and optimisation of industrial refrigeration systems. This knowledge enables us to develop and produce the best sensors!

Since its start more than 20 years ago, HB Products has attained a strong global position. This is the result of our ability to think in terms of new technological solutions, create trustworthy products, and provide a high level of service.

For further info and guidance please visit our homepage www.hbproducts.dk



Quick guide

HBLT-A1 – Liquid Level Transmitter



Functionality:

The HBLT-A1 sensor is made to measure refrigerant level in refrigeration vessels. If the HBLT-A1 is to be used in a different way, prior approval must be obtained from HB Products.

Download complete manual:

For further information please download the instruction manual from our homepage: www.hbproducts.dk.

Caution:

Only qualified personnel should work with the product. The technician must be aware of the consequences of an improperly installed sensor, and must be committed to adhering to the applicable local legislation.

Mechanical installation

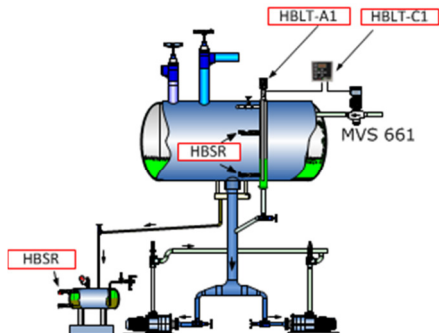

Mechanical specifications:

Ambient temperature: -20...+50°C
Liquid temperature: -50...+100°C
Max. pressure: 100 bar
Material, mechanical: AISI304/PTFE
Thread connection: see packaging.

Installation guide:

To avoid accumulation of oil in the stand pipe
a 10 deg. slope on connection pipe is recommended.

Caution! In case of welding work on the unit, the electronic part must be removed. Welding work can damage the electronics. The mechanical part of the sensor must not be installed in the pipe socket during welding.

Electrical installation

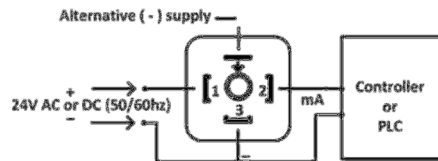

Electrical specifications:

Supply: 24 V AC/DC
Current draw: Max 50 mA
Plug: DIN 43 650
Enclosure: IP65
Material, electronics: Nylon 6 (PA).

LED indication (behind plug):

By applying power the LED will flash rapidly. At normal operation the Green LED will be flashing slowly.
Generally the Green LED is ON every time calibration pushbutton is activated.

Note! All terminals are protected against improper termination with a supply voltage up to 40 V. If the supply voltage is greater than 40 V the electronics will be damaged.

Setting of refrigerant and signal damping

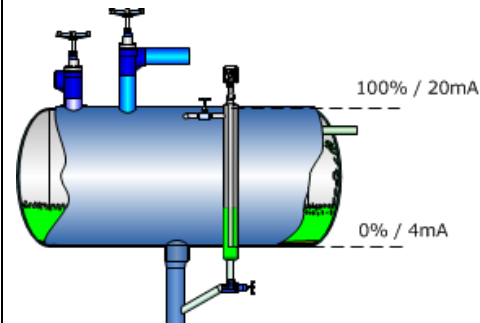

Factory calibration:

For refrigerants: R717 (NH3) / R718 (H2O) it is not necessary to change the settings. The factory setting can be used.
For use at liquid temperature's above +60°C a minimum calibration must be carried out after approx. one week of operation.

Signal damping:

Signal damping is factory set to 15 seconds. This setting can be altered by activating the calibration switch. The setting range is 1 to 120 seconds. Settings can be made whilst the system is operating

Note! Fault detection on the electronic function can be carried out without releasing pressure from the system or disassembling the mechanical part of the sensor.